

PADDLE LEVEL SWITCH

Weatherproof and Explosion Proof Option, Rotary Paddle Level Control, Top or Side Mounting for Dry Bulk Materials

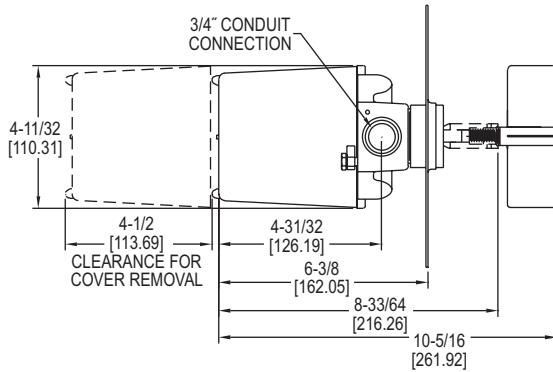

ISOLATED
MAGNETIC DRIVE

Side Mount

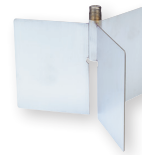

PDL-1
Minimum bulk density
of 5 lb/ft³ (80 kg/m³).



PDL-2
Minimum bulk density
of 30 lb/ft³ (481 kg/m³).



PDL-3
Minimum bulk density of 30 lb/ft³ (481 kg/m³). Fits through a 1-1/4" coupling eliminating the need for a mounting flange.



PDL-4
Minimum bulk density of 70 lb/ft³ (1122 kg/m³). Fits through 1-1/4" coupling eliminating the need for a mounting flange.



The SERIES PLS Paddle Level Switches uses a 1 rpm synchronous motor to rotate a paddle and sense the presence of dry powder or bulk materials. Movement is impeded when product comes into contact with the paddle and the resulting motor torque activates the output switches and stops the motor. The PLS is designed with the industry standard 1-1/4" male NPT connection and mounting flanges.

FEATURES/BENEFITS

- Magnetic drive isolates and completely seals the control head from the process and environment preventing material or dust from entering the control head
- Motor shuts-off when paddle stalls increasing motor life, preventing motor burnout, and decreasing power usage
- Slip clutch design enabled by the magnetic drive that prevents damage to motor and drive mechanism from sudden or excessive loading on the paddle
- Status indication light on weatherproof models
- Screw cover on the enclosure for easy access with no worries about losing bolts or screws
- Modular design to allow field installation of any paddle, flanges, shaft extensions, or shaft guards
- Flexible coupling available for protection of the paddle and drive from side loads, surges or impacts. Recommended for top mount applications with shaft extension and applications with large or heavy materials

APPLICATIONS

- Mining
- Food and beverage
- Silos
- Hoppers

MODEL CHART		
Paddle Model	Flange Model	Description
PDL-1	FLG-CSH	Carbon steel with half coupling
PDL-2	FLG-CSF	Carbon steel with full coupling
PDL-3	FLG-SSH	316 SS with half coupling
PDL-4	FLG-SSF	316 SS with full coupling

Note: Contact the factory for shaft extensions, protective shields, and other options. More detailed information available in our Measurement & Control for Powder, Dust, and Bulk Materials Catalog.

SPECIFICATIONS	
Service:	Dry powder or bulk materials compatible with wetted materials.
Sensitivity:	Min material density of 5 lb/ft ³ (80 kg/m ³), max of 200 lb/ft ³ (3200 kg/m ³).
Wetted Materials:	Paddles: 316 SS; Exposed shaft: 316 SS; Shaft seal: PTFE; Mounting boss: Aluminum; Flexible coupling: 316 SS; Mounting flanges: Carbon steel or 316 SS; Shaft extension and shaft guards: Galvanized steel or 316 SS.
Temperature Limits:	Standard construction: Process: -40 to 300°F (-40 to 148.9°C); Ambient: -40 to 185°F (-40 to 85°C); High temperature option: Process: -40 to 500°F (-40 to 260°C); Ambient: -40 to 185°F (-40 to 85°C).
Pressure Limit:	30 psig (2.07 bar) max for .5 micron or larger material.
Power Requirement:	Select by part number: 110 to 120 VAC, 230 VAC, 24 VAC, 48 VAC or 12 VDC.
Power Consumption:	Weatherproof models: 5 watts; Explosion-proof models: 3 watts.
Enclosure:	Aluminum, powder coated.
Enclosure Rating:	Weatherproof (W, WH construction): NEMA 4X (IP66); Explosion-proof (E, EH construction): NEMA 4X (IP66) and rated for Class I, Div. 1 & 2, Groups C & D, Div. 1 & 2, Groups E, F, & G.
Switch Type:	SPDT or optional DPDT snap switch.
Electrical Rating:	15 A @ 120/230 VAC.
Electric Connections:	Screw terminals.
Conduit Connection:	3/4" female NPT.
Process Connection:	1-1/4" male NPT. Optional flange.
Indication Light:	Red LED that activates when switch is made or when switch is not made with RL option (Not available on explosion-proof models).
Options:	Time delay relay, high temperature construction, top mount, shaft extensions, shaft shields, flexible couplings, other power voltages, reversed light.
Agency Approvals:	cUL approved as an auxiliary device or as an auxiliary device for hazardous locations.
Weight:	Control head only: 4 lb (1.81 kg).

MODEL CHART - CONTROL ASSEMBLIES	
Model	Description
PLS-W-S-1-0-0-0-0	Weatherproof construction, SPDT switch, 120 VAC power supply. Order paddles and flanges separately.
PLS-W-S-1-3-0-0-0	Weatherproof construction, SPDT switch, 120 VAC power supply, includes PDL-3 paddle.
PLS-W-S-1-2-CSH-0-0	Weatherproof construction, SPDT switch, 120 VAC power supply, includes PDL-2 paddle and FLG-CSH flange.

*316 SS mounting boss available.

Level Switches,
Paddle