

MODEL 166T**TELESCOPING STAINLESS STEEL PITOT TUBE**

Adjustable Design Extends Insertion Length to 36 Inches

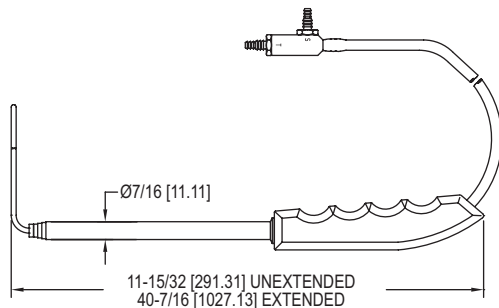

The **MODEL 166T** Telescoping Stainless Steel Pitot Tube is a unique air flow sensor which can quickly and easily be adjusted for any duct insertion length from 11.5 to 36 inches (29.2 to 91.4 cm), allowing it to replace up to 5 conventional fixed length Pitot tubes. The telescoping sections lock in place as they are extended, which enables the use of the handheld grip to gauge proper alignment of the tip with the airstream. For even greater convenience, it is securely protected by a custom fitted polyethylene carrying case.

MODEL CHART	
Model	Description
166T	Telescoping pitot tube

FEATURES/BENEFITS

- Adjustable length can replace up to 5 fixed length Pitot tubes
- Stainless steel construction resists corrosion
- 1.8" diameter hemispherical tip has 1.0 flow coefficient

APPLICATIONS

- Monitor or control air velocity or air flow when combined with differential pressure gage, switch, or transmitter where varying lengths are needed