

# ANGLE SEAT VALVE - BRONZE & STAINLESS STEEL NPT

Low Cost, Compact Design, For Use with Gases and Liquids



SAV-BT



SAV-ST

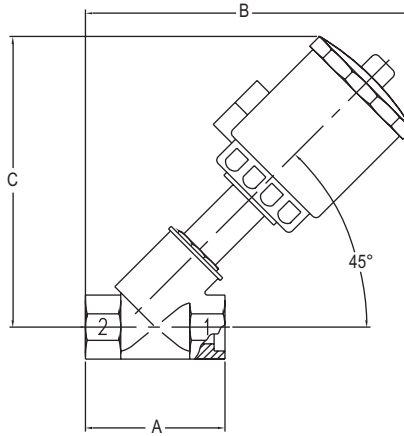

SERIES SAV-BT						
Port Connection	A	B	C	Actuator Diameter	NO Cv	NC Cv
1/2"	2.56"	6.42"	5.51"	2.76"	6.61	6.61
3/4"	2.95"	6.81"	5.79"	2.76"	12.18	12.18
1"	3.54"	8.11"	6.93"	3.32"	23.2	23.2
1-1/4"	4.33"	10.04"	8.66"	3.32"	33.06	33.64
1-1/2"	4.72"	10.63"	9.25"	4.58"	33.3	53.36
1-1/2"	4.72"	12.05"	10.67"	4.58"	-	53.94
2"	5.91"	11.02"	9.45"	4.58"	-	68.44
2"	5.91"	12.44"	10.87"	5.54"	53.94	77.72

SERIES SAV-ST						
Port Connection	A	B	C	Actuator Diameter	NO Cv	NC Cv
1/2"	3.35"	7.48"	6.14"	2.76"	6.61	6.61
3/4"	3.74"	7.68"	6.3"	2.76"	12.18	12.18
1"	4.13"	8.62"	7.17"	3.32"	23.2	23.2
1-1/4"	4.72"	10.47"	8.9"	3.32"	33.06	33.64
1-1/2"	5.12"	10.67"	9.06"	4.58"	33.3	53.36
1-1/2"	5.12"	12.09"	10.47"	4.58"	-	53.94
2"	5.91"	11.22"	9.45"	4.58"	-	68.44
2"	5.91"	12.64"	10.87"	5.54"	53.94	77.72

Save space while maintaining flow rates with the compact SERIES SAV-BT & SAV-ST Angle Seat Valves. The pneumatic, externally piloted angle seat valve is operated by a single acting actuator with a mechanical spring for failsafe operation. Select from either normally closed (NC) or normally open (NO) configurations. NO valves can be used to prevent waterhammer on valve closure in liquid applications.

**FEATURES/BENEFITS**

- Can be used in most gas, liquid and steam applications
- Integral heat sink protects Polyamide actuator
- Can be mounted in any position
- Actuator can be rotated 360° for positioning pressure ports

**SPECIFICATIONS**

**VALVE BODY**

**Service:** Gases and liquids compatible with wetted materials.  
**Wetted Materials:** Valve body: SAV-BT: Bronze; SAV-ST: AISI 316L SS; Plug and stem: AISI 316L SS; Stem O-ring: Fluoroelastomers; Seat and seal: PTFE.  
**Line Sizes:** 1/2" to 2" NPT.  
**Pressure Limits:** See table.  
**Flow Leakage:** Meets ANSI Class VI.  
**Temperature Limits:** 14 to 358°F (-25 to 180°C).

**ACTUATOR**

**Type:** Piston/pneumatic spring.  
**Pilot Connections:** NAMUR solenoid mounting pad.  
**Pilot Media:** Air, water, inert gas.  
**Pressure Limits:** See table.  
**Temperature Limit:** 185°F (85°C).

MODEL CHART					
Port Connection	Actuator Diameter	Normally Closed Model	Normally Open Model	Normally Closed Model	Normally Open Model
1/2 NPT	2.76"	SAV-BTA1-NC	SAV-BTA2-NO	SAV-STA1-NC	SAV-STA2-NO
3/4 NPT	2.76"	SAV-BTB1-NC	SAV-BTB2-NO	SAV-STB1-NC	SAV-STB2-NO
1 NPT	3.32"	SAV-BTC1-NC	SAV-BTC3-NO	SAV-STC2-NC	SAV-STC3-NO
1-1/4 NPT	3.32"	SAV-BTD3-NC	SAV-BTD3-NO	SAV-STD3-NC	SAV-STD3-NO
1-1/2 NPT	4.58"	SAV-BTE2-NC	-	SAV-STE2-NC	-
1-1/2 NPT	5.54"	SAV-BTE3-NC	SAV-BTE3-NO	SAV-STE3-NC	SAV-STE3-NO
2 NPT	4.58"	SAV-BTF2-NC	-	SAV-STF2-NC	-
2 NPT	5.54"	SAV-BTF3-NC	SAV-BTF3-NO	SAV-STF3-NC	SAV-STF3-NO

LINE AND PILOT PRESSURE CHART (PSI)											
Port Connection	Actuator Diameter	Normally Closed					Normally Open				
		Max. Line Pressure	Max. Steam Pressure	Flow Direction	Min. Pilot Pressure	Max. Pilot Pressure	Max. Line Pressure	Max. Steam Pressure	Flow Direction	Min. Pilot Pressure	Max. Pilot Pressure
1/2 NPT	2.76"	230	150	Overseat	60	143	230	150	Underseat	60	143
3/4 NPT	2.76"	230	150	Overseat	60	143	230	150	Underseat	60	143
1 NPT	3.32"	290	150	Overseat	60	143	230	150	Underseat	60	143
1-1/4 NPT	3.32"	230	150	Overseat	60	114	230	150	Underseat	60	114
1-1/2 NPT	4.58"	230	150	Overseat	60	114	230	150	Underseat	60	114
1-1/2 NPT	5.54"	230	150	Overseat	60	114	230	150	Underseat	60	114
2 NPT	4.58"	143	150	Overseat	60	114	230	150	Underseat	60	114
2 NPT	5.54"	232	150	Overseat	60	114	230	150	Underseat	60	114

USA: California Proposition 65  
 ⚠ WARNING: Cancer and Reproductive Harm - www.P65Warnings.ca.gov